

HIGH PERFORMANCE BUTTERFLY VALVE DIMENSIONS

DOUBLE FLANGE

ANSI Class 150

VALVE SIZE		A	B	L		F	Z x Z		R	S	WEIGHT (Kg)	
mm	ins	ins mm	ins mm	Long	Short	ins mm	H	G	mm	mm	Long	Short
80	3"	12,717 323	8,976 228	8,071 205	4,488 114	1,063 27	0.433*0.433 11*11		ø70	4Xø9	26	19
100	4"	14,646 372	10,157 258	9,016 229	5,00 127	1,063 27	0.551*0.551 14*14		ø70	4Xø9	34	25
125	5"	15,906 404	10,906 277	10,00 254	5,512 140	1,181 30	0.669*0.669 17*17		ø70	4Xø9	42	30
150	6"	16,969 431	11,457 291	10,512 267	5,512 140	1,260 32	0.669*0.669 17*17		ø70	4Xø9	49	34
200	8"	19,843 504	13,091 332.5	11,496 292	5,984 152	1,772 45	0.669*0.669 17*17		ø70	4Xø9	77	51
250	10"	21,693 551	13,701 348	11,811 300	6,496 165	1,969 50	0.866*0.866 22*22		ø102	4Xø11	102	78
300	12"	25,276 642	15,748 400	14,016 356	7,008 178	2,362 60	1.063*1.063 27*27		ø140	4Xø18	160	112
350	14"	29,055 738	18,150 461	15,00 381	7,520 191	2,362 60	1.063*1.063 27*27		ø140	4Xø18	198	141
400	16"	30,354 771	18,622 473	15,984 406	8,504 216	3,150 80	1.063*1.063 27*27		ø165	4Xø21	233	175
450	18"	35,670 906	23,150 588	17,008 432	8,760 222.5	3,543 90	1.417*1.417 36*36		ø165	4Xø21	272	213
500	20"	38,071 967	24,331 618	17,992 457	9,016 229	3,543 90	1.417*1.417 36*36		ø165	4Xø21	351	262
600	24"	43,189 1097	27,205 691	20,00 508	10,512 267	4,331 110	1.811*1.811 46*46		ø165	4Xø21	493	386
750	30"	50,906 1293	31,535 801	24,016 610	12,520 318	4,724 120	3.150 80	0.866 22	ø165	4Xø21	652	598
900	36"	59,409 1509	36,417 925	27,992 711	12,992 330	4,724 120	3.150 80	0.866 22	ø254	8Xø17	869	789

Flanged Valves

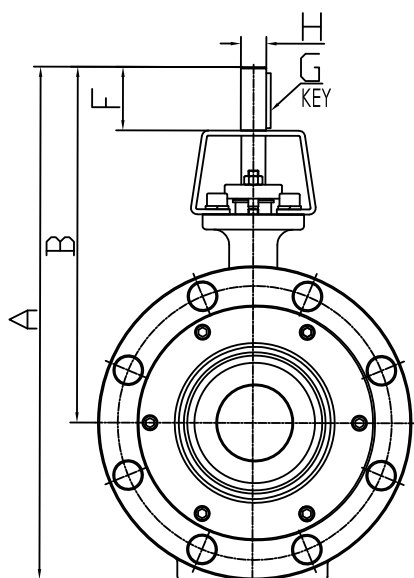

ANSI Class 300

VALVE SIZE		A	B	L		F	Z x Z		R	S	WEIGHT (Kg)	
mm	ins	ins mm	ins mm	Long	Short	ins mm	H	G	mm	mm	Long	Short
80	3"	12,717 323	8,976 228	8,071 205	4,488 114	1,063 27	0.433*0.433 11*11		ø70	4Xø9	30	21
100	4"	15,157 385	10,157 258	12,001 305	5,00 127	1.063 27	0.551*0.551 14*14		ø70	4Xø9	46	25
125	5"	16,457 418	10,906 277	15,00 381	5,512 140	1.181 30	0.669*0.669 17*17		ø70	4Xø9	59	42
150	6"	17,835 453	11,614 295	15,866 403	5,512 140	1.260 32	0.669*0.669 17*17		ø70	4Xø9	79	51
200	8"	20,472 520	12,992 330	16,496 419	5,984 152	1.969 50	0.866*0.866 22*22		ø102	4Xø11	109	83
250	10"	22,953 583	14,212 361	18,701 475	6,496 165	2.362 60	1.063*1.063 27*27		ø102	4Xø11	135	124
300	12"	27,322 694	17,047 433	19,764 502	7,008 178	2.756 70	1.063*1.063 27*27		ø140	4Xø18	211	173
350	14"	29,882 759	18,386 467	30,00 762	7,520 191	3,150 80	1.417*1.417 36*36		ø165	4Xø21	330	235
400	16"	35,827 910	23,071 586	32,992 838	8,504 216	3,150 80	1.417*1.417 36*36		ø165	4Xø21	423	329
450	18"	38,622 981	24,646 626	35,984 914	8,858 225	3,543 90	1.417*1.417 36*36		ø165	4Xø21	574	457
500	20"	53,110 1349	26,535 674	39,016 991	9,016 229	3,937 100	1.811*1.811 46*46		ø165	4Xø21	660	522
600	24"	48,740 1238	30,709 780	45,00 1143	10,433 265	4,724 120	3.150 80	0.866 22	ø254	8Xø17	862	808

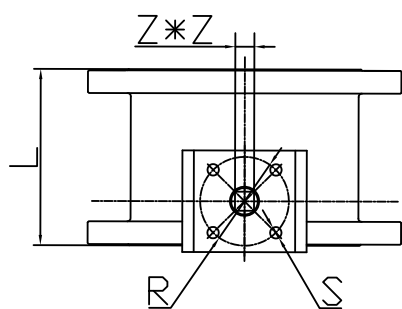

NOTE:

Drawings are for reference only. Please contact factory for separate drawing for each size.

HIGH PERFORMANCE BUTTERFLY VALVE DIMENSIONS

DOUBLE FLANGE

PN1. 6MP/PN2. 5MPa

VALVE SIZE		A	B	L		F	Z x Z		R mm	S mm	WEIGHT (Kg)	
DN	ins			Long	Short		H	G			Long	Short
80	3"	323	227	205	114	27	11*11	φ70	4Xφ9	26	19	
100	4"	373	259	229	127	27	14*14	φ70	4Xφ9	34	25	
125	5"	404	277	254	140	30	17*17	φ70	4Xφ9	42	30	
150	6"	431	291	267	140	32	17*17	φ70	4Xφ9	49	34	
200	8"	504	332	292	140	45	17*17	φ70	4Xφ9	77	51	
250	10"	551	348.2	300	165	50	22*22	φ102	4Xφ11	102	78	
300	12"	642	400	356	178	60	27*27	φ140	4Xφ18	160	112	
350	14"	738	462	381	191	60	27*27	φ140	4Xφ18	198	141	
400	16"	771	473	406	216	80	27*27	φ165	4Xφ21	233	175	
450	18"	906	589	432	223	90	36*36	φ165	4Xφ21	272	213	
500	20"	968	618	457	229	90	36*36	φ165	4Xφ21	351	262	
600	24"	1098	691	508	267	110	46*46	φ165	4Xφ21	493	386	
700	28"	1243	736		292	110	46*46	φ165	4Xφ21		420	
750	30"	1293	801	610	318	120	80	22	φ165	4Xφ21	652	598
800	32"	1368	820		318	120	80	22	φ165	4Xφ21		660
900	36"	1509	925	711	330	120	80	22	φ254	8Xφ17	869	789

Flanged Valves

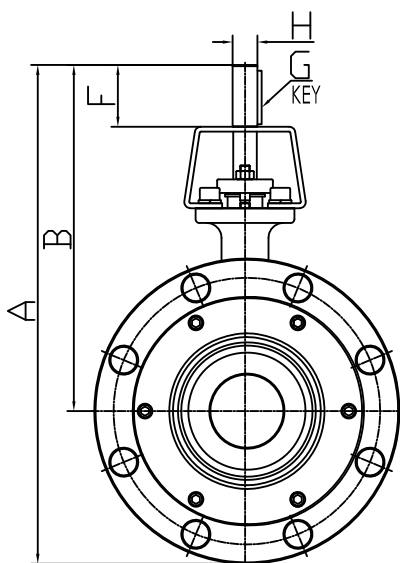

PN4. 0MPa

VALVE SIZE		A	B	L		F	Z x Z		R mm	S mm	WEIGHT (Kg)	
DN	ins			Long	Short		H	G			Long	Short
80	3"	332	228	202	114	27	11*11	φ70	4Xφ9	30	21	
100	4"	385	258	305	127	27	14*14	φ70	4Xφ9	46	25	
125	5"	418	277	381	140	30	17*17	φ70	4Xφ9	59	42	
150	6"	453	295	403	140	32	17*17	φ70	4Xφ9	79	51	
200	8"	520	330	419	152	50	22*22	φ102	4Xφ11	109	83	
250	10"	583	361	475	165	60	27*27	φ102	4Xφ11	135	124	
300	12"	694	433	502	178	70	27*27	φ140	4Xφ18	211	173	
350	14"	759	467	762	191	80	36*36	φ165	4Xφ21	330	235	
400	16"	910	586	838	216	80	36*36	φ165	4Xφ21	423	329	
450	18"	981	625	914	225	90	36*36	φ165	4Xφ21	574	457	
500	20"	1349	674	991	229	100	46*46	φ165	4Xφ21	660	522	
600	24"	1238	780	1143	265	120	80	22	φ254	8Xφ17	862	808

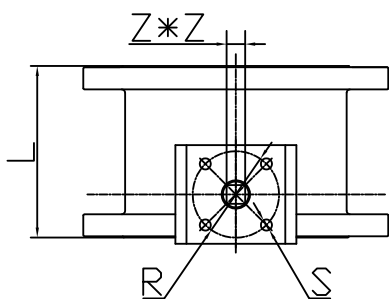

NOTE:

Drawings are for reference only. Please contact factory for separate drawing for each size.